

Reg.No.:



VIVEKANANDHA COLLEGE OF ENGINEERING FOR WOMEN

[AUTONOMOUS INSTITUTION AFFILIATED TO ANNA UNIVERSITY, CHENNAI]

Elayampalayam – 637 205, Tiruchengode, Namakkal Dt., Tamil Nadu.

**Question Paper Code: 120006**

B.E. / B.Tech. DEGREE END-SEMESTER EXAMINATIONS – NOV. / DEC. 2024

Fifth Semester

Biomedical Engineering

U19BM509 – BIO CONTROL SYSTEMS

(Regulation 2019)

Time: Three Hours

Maximum: 100 Marks

Answer ALL the questions

Knowledge Levels (KL)	K1 – Remembering	K3 – Applying	K5 - Evaluating
	K2 – Understanding	K4 – Analyzing	K6 - Creating

PART – A

(10 x 2 = 20 Marks)

Q.No.	Questions	Marks	KL	CO
1.	How are physiological control systems more complex than engineering control systems?	2	K2	CO1
2.	List the properties of signal flow graph.	2	K1	CO1
3.	A step input is given for the system with transfer function $\frac{C(s)}{R(s)} = \frac{36}{s^2+2s+36}$ . Find the settling time and peak overshoot.	2	K3	CO2
4.	State the necessary conditions for stability according to Routh stability criterion.	2	K1	CO2
5.	Define the gain cross over frequency and phase margin.	2	K1	CO3
6.	A second-order system has a damping ratio of 0.5 and an undamped natural frequency of 8 rad/sec. Calculate the resonant frequency.	2	K3	CO3
7.	How does the oculo-motor system coordinate eye movements with head and body movements?	2	K2	CO4
8.	How is the chest wall incorporated into models of respiratory mechanics?	2	K2	CO4
9.	Differentiate between transient and steady state analysis.	2	K2	CO5
10.	Why is stability analysis important in modeling the pupillary light reflex, and what factors could lead to its destabilization?	2	K2	CO5

PART – B

(5 x 13 = 65 Marks)

Q.No.	Questions	Marks	KL	CO
11. a)	Using block diagram reduction techniques, find the closed loop transfer function for the block diagram shown below.	13	K3	CO1

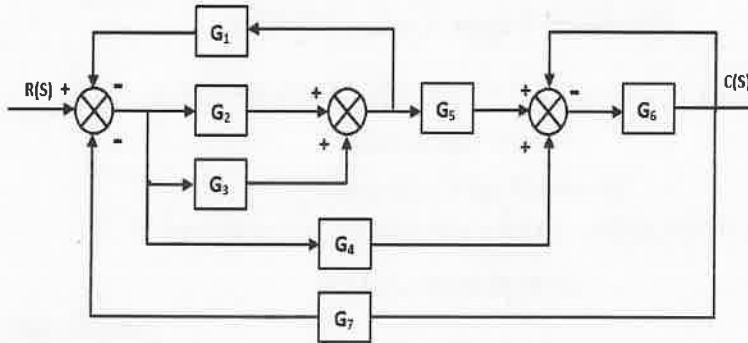

(OR)

b)	Consider the linearized physiological model of skeletal muscle, where $F_o$ is the force from the active contractile element, $F$ is the actual force, $R$ represents viscous damping, and $C_p$ and $C_s$ are the elastic elements, derive the differential equation relating $F$ to $x$ and $F_o$ . What does this model predict under steady-state isometric conditions?	13	K3	CO1
12. a)	A system has a closed loop transfer function $T(s) = \frac{361}{s^2+16s+361}$ . Find the rise time, peak time, peak overshoot and settling time for 2% tolerance.	13	K3	CO2

(OR)

b)	Sketch the root locus of a unity feedback system with open loop transfer function $G(s) = \frac{K}{s(s^2+8s+32)}$ .	13	K3	CO2
13. a)	Plot the Bode diagram for the given transfer function and determine: <ol style="list-style-type: none"> <li>the gain and phase crossover frequencies, and</li> <li>the gain and phase margins. <math>G(s) = \frac{10}{s(0.4s+1)(0.1s+1)}</math>.</li> </ol>	13	K3	CO3

(OR)

b)	Using Nyquist stability criterion determine the stability of the closed loop system, when open loop transfer function is given by $G(s) = \frac{(s+2)}{(s+1)(s-1)}$ . Comment on the stability of open loop and closed loop system.	13	K3	CO3
----	---	----	----	-----

14.	a)	Analyze the role of feedback mechanisms in cardiovascular regulations.	13	K4	CO4
		(OR)			
	b)	With a clear diagram, explain how the skeletal muscle servomechanism regulates muscle force and movement.	13	K4	CO4
15.	a)	Develop a simplified model of the cardiac output regulation system, derive the expression for cardiac output, and plot the resulting curve.	13	K4	CO5
		(OR)			
	b)	Analyze the steady-state behavior of the muscle stretch reflex. How does this analysis help in understanding the regulation of muscle length and reflexive muscle control?	13	K4	CO5

PART – C

(1 x 15 = 15 Marks)

Q.No.	Questions	Marks	KL	CO
16.	a) Develop a temperature regulation model of a biological systems. Explain the key components and their roles in maintaining homeostasis.	15	K4	CO4
	(OR)			
	b) How does chemoreflex regulation control respiration, particularly through the levels of PaCO <sub>2</sub> and PaO <sub>2</sub> ? Describe the role of the gas-exchanging and respiratory controller of the model and their respective input-output characteristics.	15	K4	CO5